

# Сетчатые фильтры SKF 352-359 серии 350

## Технические характеристики

По вопросам продаж и поддержки обращайтесь:

Алматы (727)345-47-04  
Ангарск (3955)60-70-56  
Архангельск (8182)63-90-72  
Астрахань (8512)99-46-04  
Барнаул (3852)73-04-60  
Белгород (4722)40-23-64  
Благовещенск (4162)22-76-07  
Брянск (4832)59-03-52  
Владивосток (423)249-28-31  
Владикавказ (8672)28-90-48  
Владимир (4922)49-43-18  
Волгоград (844)278-03-48  
Вологда (8172)26-41-59  
Воронеж (473)204-51-73  
Екатеринбург (343)384-55-89

Иваново (4932)77-34-06  
Ижевск (3412)26-03-58  
Иркутск (395)279-98-46  
Казань (843)206-01-48  
Калининград (4012)72-03-81  
Калуга (4842)92-23-67  
Кемерово (3842)65-04-62  
Киров (8332)68-02-04  
Коломна (4966)23-41-49  
Кострома (4942)77-07-48  
Краснодар (861)203-40-90  
Красноярск (391)204-63-61  
Курск (4712)77-13-04  
Курган (3522)50-90-47  
Липецк (4742)52-20-81

Магнитогорск (3519)55-03-13  
Москва (495)268-04-70  
Мурманск (8152)59-64-93  
Набережные Челны (8552)20-53-41  
Нижний Новгород (831)429-08-12  
Новокузнецк (3843)20-46-81  
Ноябрьск (3496)41-32-12  
Новосибирск (383)227-86-73  
Омск (3812)21-46-40  
Орел (4862)44-53-42  
Оренбург (3532)37-68-04  
Пенза (8412)22-31-16  
Петрозаводск (8142)55-98-37  
Псков (8112)59-10-37  
Пермь (342)205-81-47

Ростов-на-Дону (863)308-18-15  
Рязань (4912)46-61-64  
Самара (846)206-03-16  
Санкт-Петербург (812)309-46-40  
Саратов (845)249-38-78  
Севастополь (8692)22-31-93  
Саранск (8342)22-96-24  
Симферополь (3652)67-13-56  
Смоленск (4812)29-41-54  
Сочи (862)225-72-31  
Ставрополь (8652)20-65-13  
Сургут (3462)77-98-35  
Сыктывкар (8212)25-95-17  
Тамбов (4752)50-40-97  
Тверь (4822)63-31-35

Тольятти (8482)63-91-07  
Томск (3822)98-41-53  
Тула (4872)33-79-87  
Тюмень (3452)66-21-18  
Ульяновск (8422)24-23-59  
Улан-Удэ (3012)59-97-51  
Уфа (347)229-48-12  
Хабаровск (4212)92-98-04  
Чебоксары (8352)28-53-07  
Челябинск (351)202-03-61  
Череповец (8202)49-02-64  
Чита (3022)38-34-83  
Якутск (4112)23-90-97  
Ярославль (4852)69-52-93

Россия +7(495)268-04-70

Казахстан +(727)345-47-04

Беларусь +(375)257-127-884

Узбекистан +998(71)205-18-59

Киргизия +996(312)96-26-47

эл.почта: [khc@nt-rt.ru](mailto:khc@nt-rt.ru) || сайт: <https://krombach.nt-rt.ru/>



### **SiebkorbfILTER mit Flanschanschluss PN 10 bis PN 40**

wahlweise mit Schweißenden nach EN 12627. Gehäuse in Schweißkonstruktion.

Baulänge nach DIN EN 558, Grundreihe 1.

Siebeinsatz als stabiler Siebkorb aus gelochtem Blech und eingelegtem Edelstahl-Drahtgewebe, Maschenweite ca. 0,96 mm, Werkstoff-Nr. 1.4401. Die freie Siebfläche entspricht ca. dem 3-fachen Anschlussquerschnitt.

Entlüftungstopfen im Verschlussdeckel und Entleerungstopfen im Gehäuseboden. Flanschanschlussmaße und Bohrungen nach EN 1092-1, Dichtleiste nach EN 1092-1 Form B1.

### **Basket type strainers with flanged connection PN 10 up to PN 40**

on request with welding ends acc. to EN 12627. Body in welded construction.

Face to face dimensions acc. to DIN EN 558 series 1.

Screen insert as solid screen basket made of perforated steel plate and inserted stainless steel wire cloth, mesh size approx. 0,96 mm, material-no. 1.4401. The free screen area corresponds to approx. the 3-fold connection cross section. Vent plug in the sealing cover and drain plug in the bottom of the body.

Flange dimensions and drillings acc. to EN 1092-1, sealing surface acc. to EN 1092-1 form B1.

Flange connection measured and drilled acc. to EN 1092-1, sealing surface acc. to EN 1092-1 form B1.

# Series 350

# Siebkorbfilter Basket type strainers

Bestell-Nr. Order-no.	PN	Gehäusewerkstoffe Body materials	Deckel Cover	Siebkorb Screen basket	Drahtgewebe Wire cloth
SKF 352	10	P235G1TH (St35.8) 1.0305 P250GH (C22.8) 1.0460 P265GH (HII) 1.0425	P265GH (HII) 1.0425	<u>bis / up to DN 300:</u> X6CrNiMoTi17-12-2 1.4571	X4CrNiMo17-12-2 1.4401
SKF 353	16				
SKF 354	25			<u>ab / from DN 350:</u> S235JRG2(RSt 37-2) 1.0038	
SKF 355	40				
SKF 356	10	X6CrNiMoTi17-12-2 1.4571	X6CrNiMoTi17-12-2 1.4571	X6CrNiMoTi17-12-2 1.4571	X4CrNiMo17-12-2 1.4401
SKF 357	16				
SKF 358	25				
SKF 359	40				

# Siebkorbfilter Basket type strainers

Series 350

Ausführung bis DN 300  
Design up to DN 300

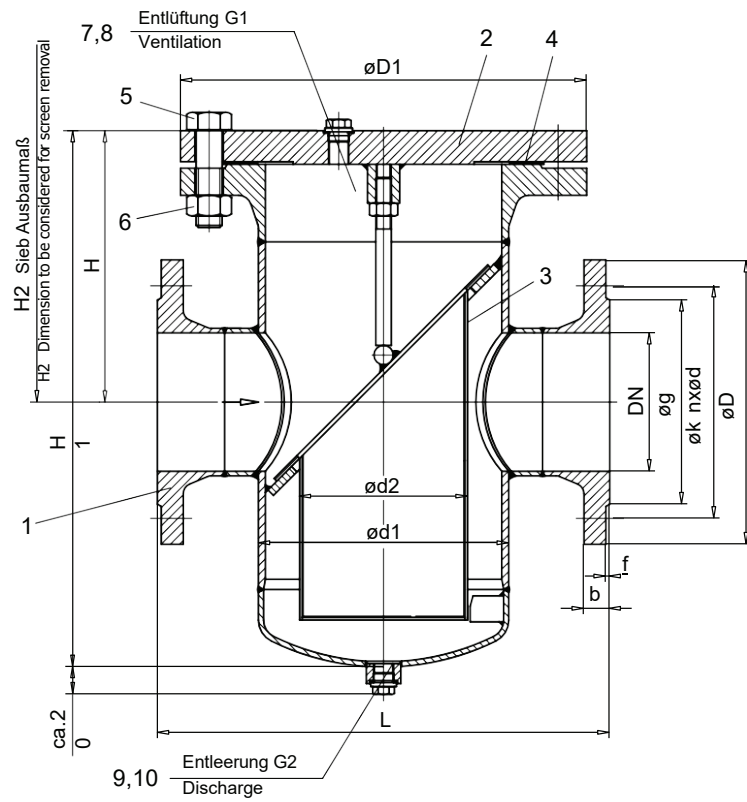

Ausführung ab DN 350  
Design from DN 350

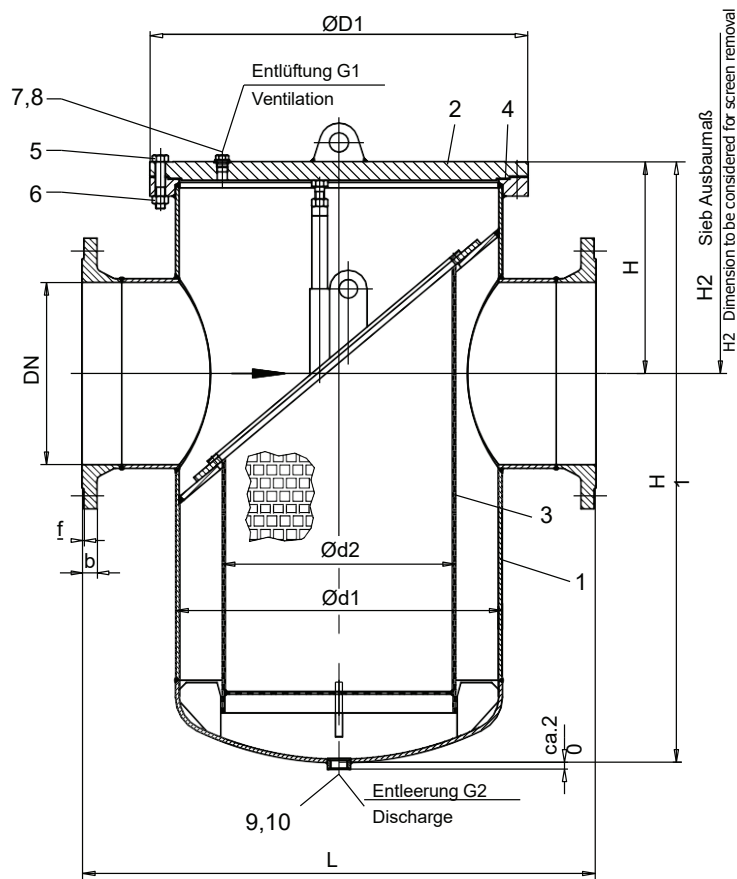

## Baumaße und Gewichte / Dimensions and weights

DN	PN	Baumaße / Dimensions									Flanschanschlussmaße / Flange dimensions						Gewicht Weight ... [kg]*
		L	D	d1	d2	H	H1	H2	E1	E2	D	k	nxd	g	b	f	
50	10	230	220	114,3	80	155	270	330	G 3/8	G 1/2	165	125	4x18	102	18	3	29
	16		220								165	125	4x18	102	18	3	
	25		235								165	125	4x18	102	20	3	
	40		235								165	125	4x18	102	20	3	
65	10	290	250	139,7	98	175	300	385	G 3/8	G 1/2	185	145	4x18	122	18	3	40
	16		250								185	145	4x18	122	18	3	
	25		270								185	145	8x18	122	22	3	
	40		270								185	145	8x18	122	22	3	
80	10	310	285	168,3	110	185	340	445	G 3/8	G 1/2	200	160	8x18	138	20	3	45
	16		285								200	160	8x18	138	20	3	
	25		300								200	160	8x18	138	24	3	
	40		300								200	160	8x18	138	24	3	
100	10	350	315	193,7	130	225	390	510	G 3/8	G 1/2	220	180	8x18	158	20	3	69
	16		315								220	180	8x18	158	20	3	
	25		330								235	190	8x22	162	24	3	
	40		350								235	190	8x22	162	24	3	
125	10	400	340	219,1	140	245	490	630	G 3/8	G 1/2	250	210	8x18	188	22	3	96
	16		340								250	210	8x18	188	22	3	
	25		360								270	220	8x26	188	26	3	
	40		375								270	220	8x26	188	26	3	
150	10	480	395	273	185	280	570	730	G 1/2	G 3/4	285	240	8x22	212	22	3	168
	16		405								285	240	8x22	212	22	3	
	25		425								300	250	8x26	218	28	3	
	40		450								300	250	8x26	218	28	3	
200	10	600	505	356	250	270	750	780	G 1/2	G 3/4	340	295	8x22	268	24	3	228
	16		520								340	295	12x22	268	24	3	
	25		555								360	310	12x26	278	30	3	
	40		580								375	320	12x30	285	34	3	
250	10	730	565	406	280	295	820	900	G 1/2	G 1	395	350	12x22	320	26	3	302
	16		580								405	355	12x26	320	26	3	
	25		620								425	370	12x30	335	32	3	
	40		660								450	385	12x33	345	38	3	

300	10	850	670	508	380	350	870	945	G 1/2	G 1	445	400	12x22	370	26	4	450
	16		715								460	410	12x26	378	28	4	
	25		730								485	430	16x30	395	34	4	
	40		755								515	450	16x33	410	42	4	
350	10	980	780	610	420	430	1180	1300	G 1/2	G 1 1/2	505	460	16x22	430	26	4	770
	16		840								520	470	16x26	438	30	4	
	25		845								555	490	16x33	450	38	4	
	40		890								580	510	16x36	465	46	4	
400	10	1100	895	711	500	475	1375	1450	G 1/2	G 1 1/2	565	515	16x26	482	26	4	870
	16		910								580	525	16x30	490	32	4	
	25		960								620	550	16x36	505	40	4	
	40		995								660	585	16x39	535	50	4	
500	10	1250	1115	914	630	600	1570	1800	G 1/2	G 1 1/2	670	620	20x26	585	28	4	1285
	16		1125								715	650	20x33	610	34	4	
	25		1185								730	660	20x36	615	44	4	
	40		1250								755	670	20x42	615	52	4	
600	10	1450	1230	1016	700	690	1945	2130	G 3/4	G 1 1/2	780	725	20x30	685	28	5	2010
	16		1255								840	770	20x36	725	36	5	
	25		1320								845	770	20x39	720	46	5	
	40		1360								890	795	20x48	735	60	5	

### Werkstoffe / Materials

Pos / Item	Benennung	Designation	SKF 352 - SKF 355		SKF 356 - SKF 359	
			Werkstoff / Material	W.-Nr./M.-No.	Werkstoff / Material	W.-Nr./M.-No.
1	Gehäuse	Body	P235G1TH (St 35.8) P250GH (C22.8) P265GH (HII)	1.0305 1.046 1.0425	X6CrNiMoTi17-12-2	1.4571
2	Deckel	Cover	P265GH (HII)	1.0425	X6CrNiMoTi17-12-2	1.4571
3.1	gelochtes Blech	Perforated plate	bis/up to DN 300: X6CrNiMoTi17-12-2 ab/from DN 350: S235JRG2 (RSt 37-2)	1.4571 1.0038	X6CrNiMoTi17-12-2	1.4571
3.2	Drahtgewebe	Wire cloth	X4CrNiMo17-12-2	1.4401	X4CrNiMo17-12-2	1.4401
4*	Dichtung	Sealing	asbestfrei / Asbestos free	-	asbestfrei / Asbestos free	-
5	Sk-Schraube	Hex-head screw	5.6	-	A4-70	-
6	Sk-Mutter	Hex-nut	5-2	-	A4	-
7*	Dichtung	Sealing	asbestfrei / Asbestos free	-	asbestfrei / Asbestos free	-
8	Verschlusschraube	Plug	5.6	-	A4-70	-
9*	Dichtung	Sealing	asbestfrei / Asbestos free	-	asbestfrei / Asbestos free	-
10	Verschlusschraube	Plug	5.6	-	A4-70	-

\* Ersatzteile / Spare parts

Ausführung mit Schnellverschlussdeckel, Schwenkeinrichtung und Differenzdruckanzeige  
Design with quick acting cover, swing device and differential pressure indicator

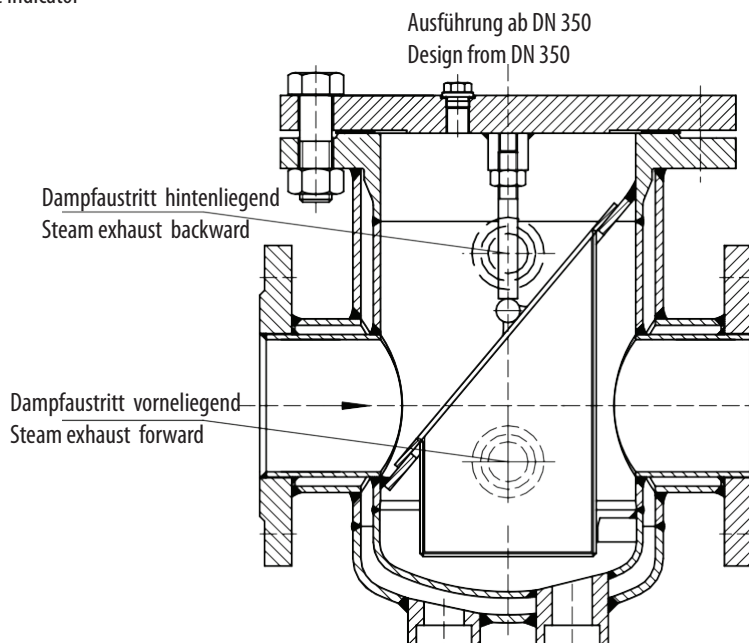
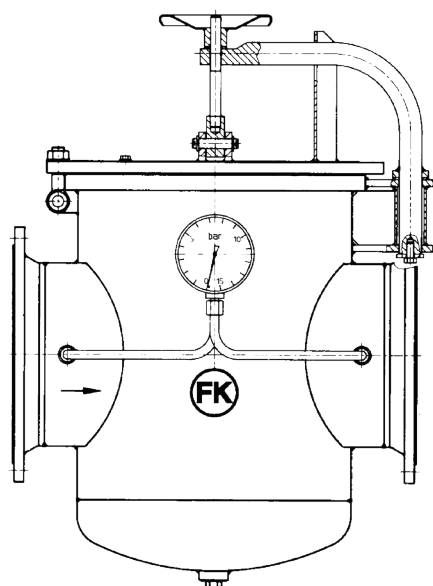

Bestell-Nr. Order-no.	PN	Wasser-Prüfdruck im Gehäuse Water test pressure at the body [bar]	max. Betriebsdruck in bar Max. working pressure in bar						
			20°C	50°C	120°C	150°C	200°C	250°C	300°C
SKF 352	10	15	10	10	10	9	8	7	6
SKF 353	16	24	16	16	16	15	14	13	11
SKF 354	25	38	25	25	25	23	22	20	17
SKF 355	40	60	40	40	40	37	35	32	28
SKF 356	10	15	10	10	9,5	9,1	8,5	8,1	7,8
SKF 357	16	24	16	16	15,2	14,6	13,7	13	12,4
SKF 358	25	38	25	25	23,8	22,8	21,3	20,3	19,4
SKF 359	40	60	40	40	38	36,4	34,1	32,5	31,1

DN	50	65	80	100	125	150	200	250	300	400	500	600
Zeta-Wert	3,1	3,1	3,2	3,2	3,4	3,5	3,5	3,5	3,6	3,5	3,5	3,2
Kvs-Wert in m <sup>3</sup> /h	57	96	143	223	338	480	854	1334	1895	3417	5338	8040

Der max. zul. Differenzdruck beträgt 2 bar. Die max. zul. Strömungsgeschwindigkeit beträgt 2,5 m/s (Wasser).  
The max. allowable differential pressure is 2 bar. The max. allowable flow rate is 2,5 m/s (water).

### Lieferbare Sonderausführungen:

- mit anderen Maschenweiten
- mit Standfüßen
- weitere Nennweiten auf Anfrage
- andere Werkstoffe
- mit höhenversetzten Ein- / Auslaufstutzen
- mit Schweißenden

### Available special designs:

- With other mesh
- With stand
- Further nominal diameters on request
- Other materials
- With shifted height at inlet and outlet connection
- With welding ends

## По вопросам продаж и поддержки обращайтесь:

Алматы (727)345-47-04  
Ангарск (3955)60-70-56  
Архангельск (8182)63-90-72  
Астрахань (8512)99-46-04  
Барнаул (3852)73-04-60  
Белгород (4722)40-23-64  
Благовещенск (4162)22-76-07  
Брянск (4832)59-03-52  
Владивосток (423)249-28-31  
Владикавказ (8672)28-90-48  
Владимир (4922)49-43-18  
Волгоград (844)278-03-48  
Вологда (8172)26-41-59  
Воронеж (473)204-51-73  
Екатеринбург (343)384-55-89

Иваново (4932)77-34-06  
Ижевск (3412)26-03-58  
Иркутск (395)279-98-46  
Казань (843)206-01-48  
Калининград (4012)72-03-81  
Калуга (4842)92-23-67  
Кемерово (3842)65-04-62  
Киров (8332)68-02-04  
Коломна (4966)23-41-49  
Кострома (4942)77-07-48  
Краснодар (861)203-40-90  
Красноярск (391)204-63-61  
Курск (4712)77-13-04  
Курган (3522)50-90-47  
Липецк (4742)52-20-81

Магнитогорск (3519)55-03-13  
Москва (495)268-04-70  
Мурманск (8152)59-64-93  
Набережные Челны (8552)20-53-41  
Нижний Новгород (831)429-08-12  
Новокузнецк (3843)20-46-81  
Ноябрьск (3496)41-32-12  
Новосибирск (383)227-86-73  
Омск (3812)21-46-40  
Орел (4862)44-53-42  
Оренбург (3532)37-68-04  
Пенза (8412)22-31-16  
Петрозаводск (8142)55-98-37  
Псков (8112)59-10-37  
Пермь (342)205-81-47

Ростов-на-Дону (863)308-18-15  
Рязань (4912)46-61-64  
Самара (846)206-03-16  
Санкт-Петербург (812)309-46-40  
Саратов (845)249-38-78  
Севастополь (8692)22-31-93  
Саранск (8342)22-96-24  
Симферополь (3652)67-13-56  
Смоленск (4812)29-41-54  
Сочи (862)225-72-31  
Ставрополь (8652)20-65-13  
Сургут (3462)77-98-35  
Сыктывкар (8212)25-95-17  
Тамбов (4752)50-40-97  
Тверь (4822)63-31-35

Тольятти (8482)63-91-07  
Томск (3822)98-41-53  
Тула (4872)33-79-87  
Тюмень (3452)66-21-18  
Ульяновск (8422)24-23-59  
Улан-Уда (3012)59-97-51  
Уфа (347)229-48-12  
Хабаровск (4212)92-98-04  
Чебоксары (8352)28-53-07  
Челябинск (351)202-03-61  
Череповец (8202)49-02-64  
Чита (3022)38-34-83  
Якутск (4112)23-90-97  
Ярославль (4852)69-52-93

Россия +7(495)268-04-70

Казахстан +(727)345-47-04

Беларусь +(375)257-127-884

Узбекистан +998(71)205-18-59

Киргизия +996(312)96-26-47

эл.почта: [khc@nt-rt.ru](mailto:khc@nt-rt.ru) || сайт: <https://krombach.nt-rt.ru/>